

SCREW: NONE	MATERIAL: COPPER	REV: 0	 800-776-9775 www.ilSCO.com
CAT. NO.: SEE CHART	PLATING: EL-TIN	DRAWN BY: DW SCALE: 2:1	
INFORMATION SHEET: FORM 157	MARKING: SEE BELOW	DATE: 7/19/2007 SIZE: B	
			DWG NO: Y0103-S
			SHEET: 1 OF 1

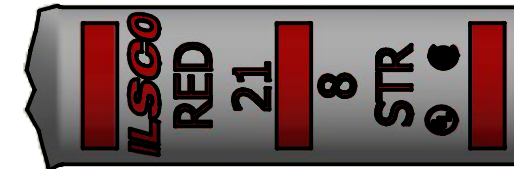

DETAIL C
TOP & BOTTOM INK MARKING

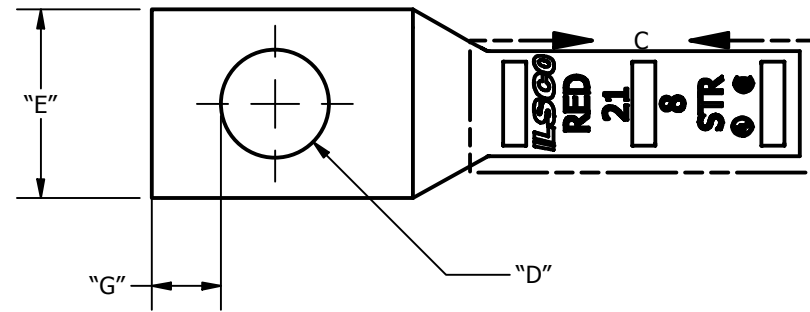
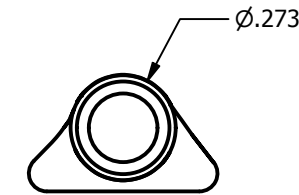
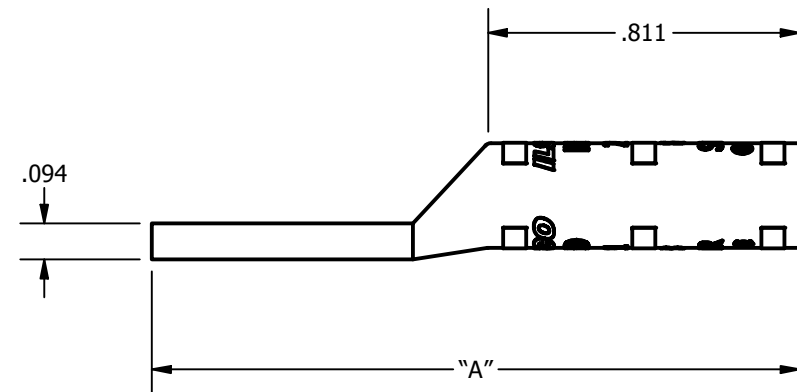

CATALOG NUMBER	"A"	"D"	"E"	"G"	TANG MARKING
CLNS-8-8	1.569	0.195	0.374	0.129	
CLNS-8-10	1.569	0.219	0.374	0.148	ILSCO, C-8-10, 8 STR, UL, CSA
CLNS-8-14	1.687	0.281	.491	0.180	ILSCO, C-8-14, 8 STR, UL, CSA
CLNS-8-14-BA	1.687	0.281	.491	0.180	ILSCO, C-8-14, 8 STR, UL, CSA
CLNS-8-516	1.882	0.343	.535	0.180	ILSCO, CLNS-8-516, 8 STR, DIE 21, UL, CSA
CLNS-8-38	1.882	0.406	.598	0.211	ILSCO, CLNS-8-38, 8 STR, DIE 21, UL, CSA
CLNS-8-12	2.257	0.562	.755	0.265	ILSCO, CLNS-8-12, 8 STR, DIE 21, UL, CSA